

○ Hello  
○ Skully

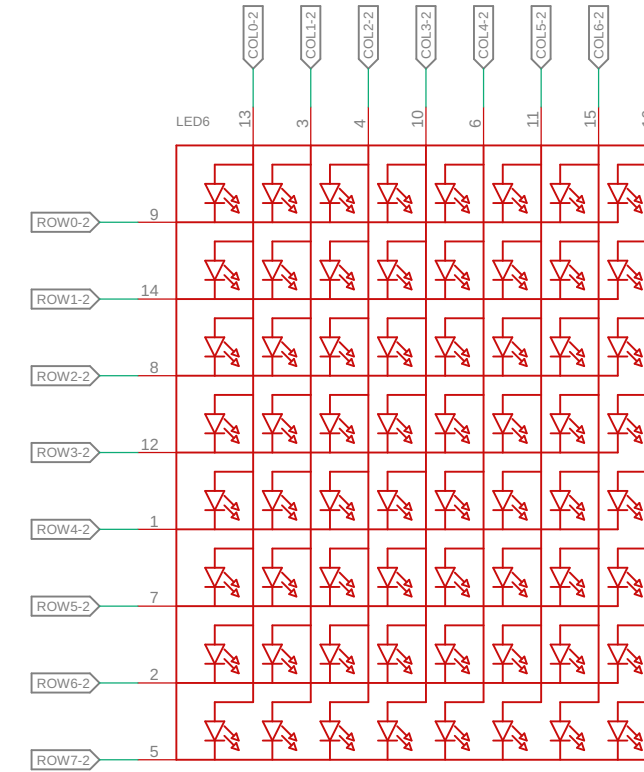
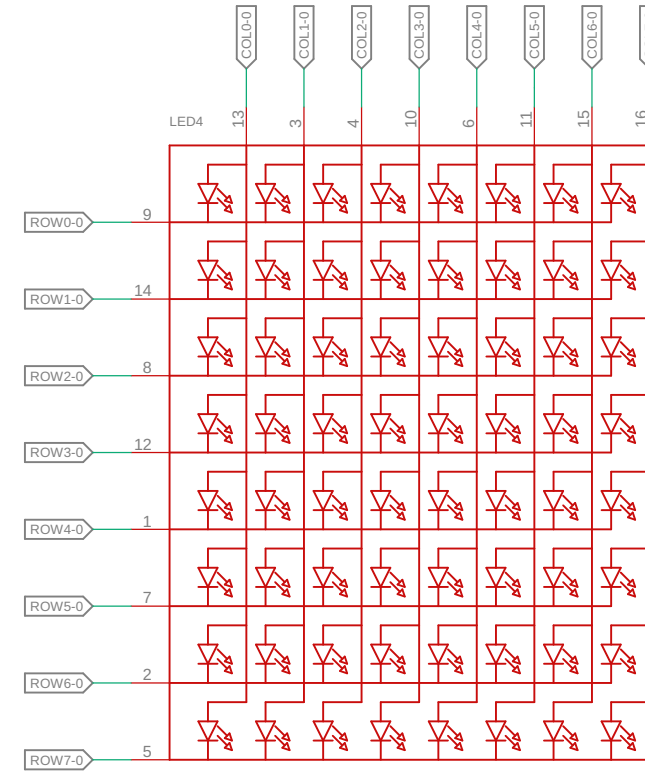
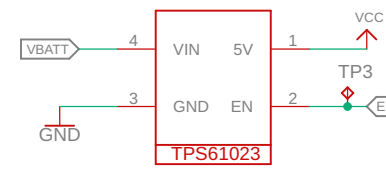
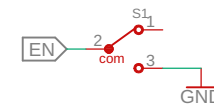
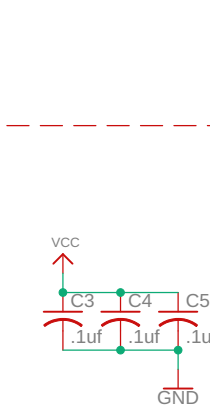

bypass/filtering

indication, boost, switch

KMV-3088 8x8 LED matrix

R4, R5, R6 set the current to the led matrix.  
Suggested values are for the following colours to achive 20ma current draw pwer segment. A hex value can lower the brightness further in software.

Red: 26k  
Green: 27k  
Blue: 22.6k  
White: 24k

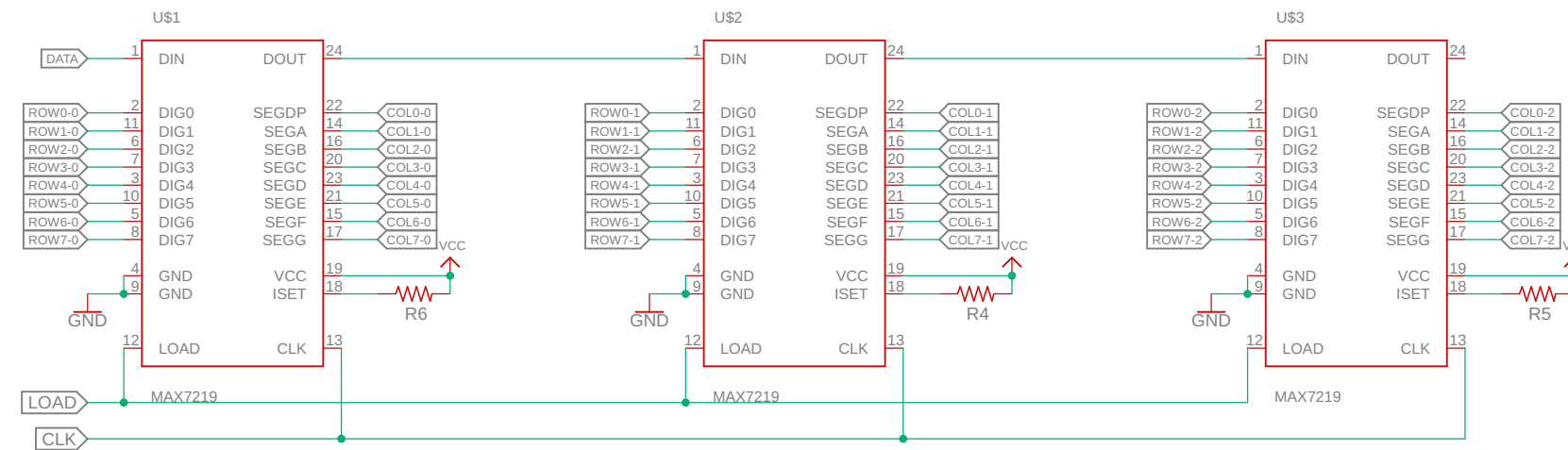

LED multiplexer and driver

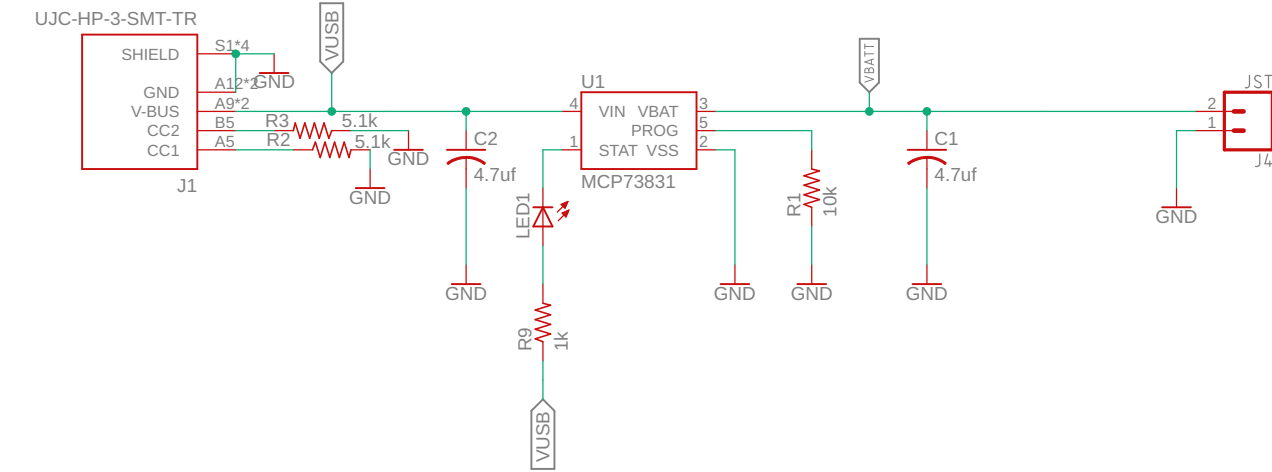

USBC lipo charging and indication

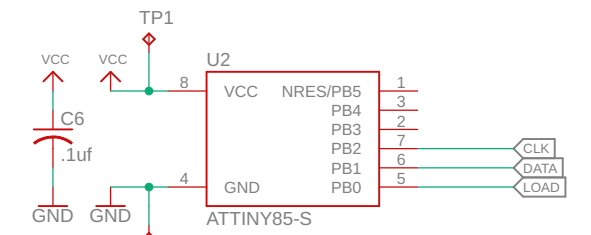

MCU

HELLO MY NAME IS rev D	
DATE 27/11/2021 10:00	SHEETS 1/1
DRAWINGS Madison Holmberg	